

Baler ARTechnic PBe15



Advantages of the machine:

- **The moving of the pressing plate is kept extremely rigid and straight.** The hydraulic cylinder does not take the bending forces from the pressing plate, which could lead to its damage. These forces are taken over by special plastic guides which are tailored to the corners of the chamber. The guides are made from specially chosen plastic, which is characterized by very high resistance to abrasion. Therefore, these elements are extremely durable. This avoids the need to control the tilt of the pressing plate. Because of all this you can easily exploit our machines, even for very demanding materials, without worrying of an improperly use of the machine.

- **The steel construction** of our machines is designed to withstand loads far in excess of the rated load for the different models (this is why our machines have a generally bigger own mass compared to the competition)

- **A system to prevent the decompressing of material** after subsequent cycles of work.

- **Possibility to bind the packages (bales) with all commonly used materials** like a polyester tape, twine or steel wire;

- **The possibility of producing specified machines** concerning the customer's request e.g. changes in the stroke of the pressing plate, changes

in the loading hole, changes in the size of the bale, etc.

- **Possibility to choose the version of the controller** and to choose additional options, depending on individual needs

- **Unmanned and durable** hydraulic system

- **No hidden costs** of operating the machine

Technical specification

Number of chambers:	single	Loading:	frontal
Charging hole:	420 x 350 mm	Bale tying:	manual
Max. pressure:	15kN (1,5 tons)	Bale launch:	manual – by a special truck
Unit pressure:	0,94 kg/cm ²	Supply:	230/50 [V/Hz]
Bale dimensions:	400 x 400 x 500	Engine power:	1,5 kW
Bale weight:	ca. 10 – 30 kg	Work cycle:	ca. 24 seconds
Productivity:	ca. 3 – 4 bale/h.	Weight:	300 kg

Dimension

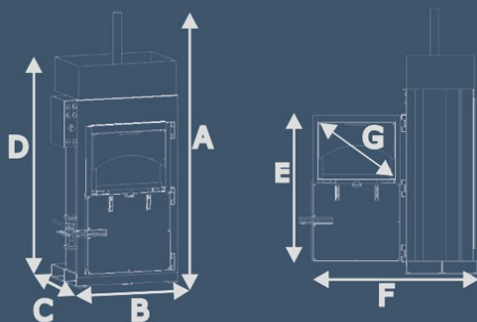

LEGEND		[mm]
A	height	1800
B	width	800
C	depth	500
D	transport height	1400
E	door height	800
F	depth with open door	1100
G	filling inlet	420 x 350

Available steering types

Steering p (PLUS)

Features

- Controller PLC
- Automatic digital steering of the work cycle
- Finished-bale signal

Control Panel

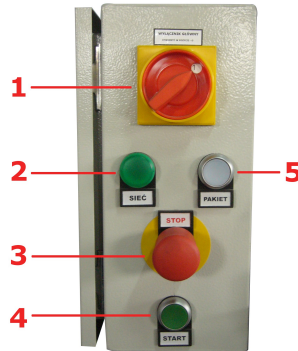

1. Main switch
2. A green light indicates a connection of the bale to power and that the main switch is turned ON
3. Emergency "STOP" switch
4. Button "START" starts the pressing process
5. The white light "PACKET" indicates that the press has achieved the maximum filling

Gallery



Contact

Headquarter

ARTechnic
ul. Gen. St. Maczka 9
43-300 Bielsko-Biała
Poland

Phones

Tel. +48 (33) 816 01 69
fax +48 (33) 443 20 46

E-mail and Web Site

biuro@artehnic.pl
www.artehnic.pl
www.belowniceuzywane.pl